

All at Sea

IoT challenges in the maritime sector



Andy Jones CISSP

Distinguished Analyst Information Security Forum

About the Information Security Forum

An international association of over 470 leading global organisations that:

- addresses key issues in information risk management through research and collaboration
- remains a fully independent, not-for-profit organisation driven by its Members
- develops practical tools and guidance
- promotes networking within its Membership.

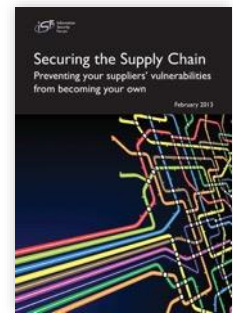
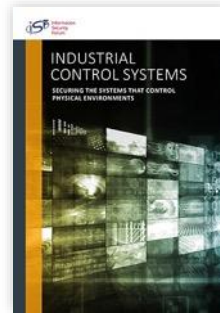

**THE LEADING AUTHORITY ON CYBER SECURITY
AND INFORMATION RISK MANAGEMENT**

From the high seas...

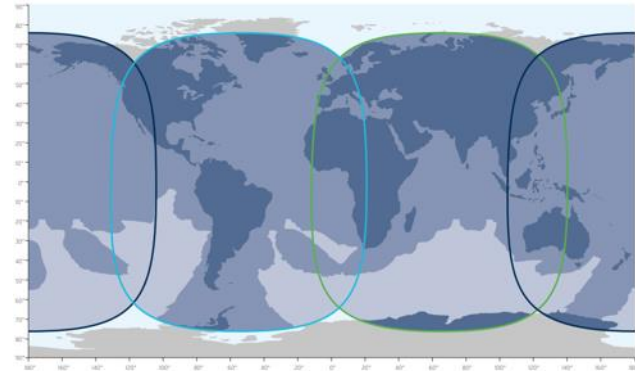
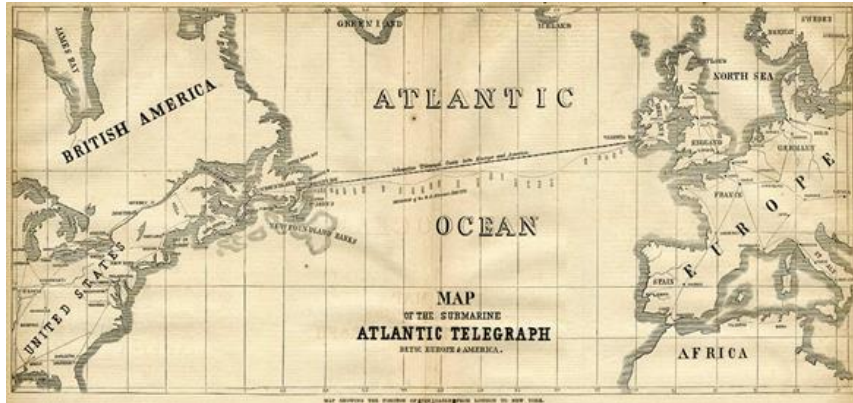

...to the cyber-seas

Maritime is on-line

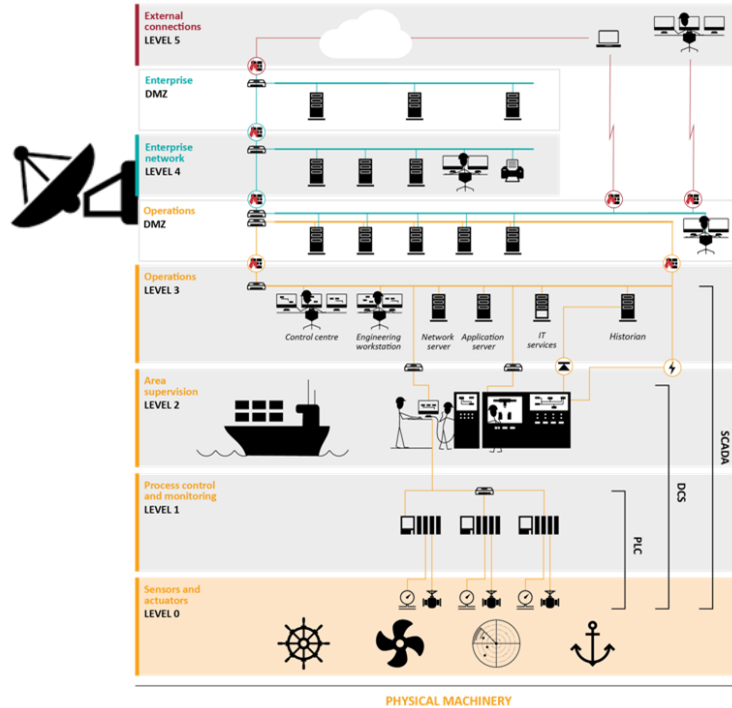

and IoT deployment is accelerated

The datacentre on water



Rewards

- Customer visibility (cargo)
- Predicative Maintenance
- Navigation improvements
- Bunker efficiencies
- Fleet management
- Autonomous vessels
- Customer engagement (cruise)

Risks

- Cyber piracy
- Hacks
- Extortion
- Malware

Targets

- IoT
- ICS
- GPS
- ECDIS
- AIS
- Satellite
- Third parties
- Pax

Sources: <https://www.freightwaves.com/news/shipping-cyber-terrorism-threat-heightened-by-digitalization>
<https://www.maritime-executive.com/article/tests-show-ease-of-hacking-ecdis-radar-and-machinery>
<https://www.workboat.com/news/bluewater/most-large-maritime-companies-have-been-cyber-targets/>

A perfect storm

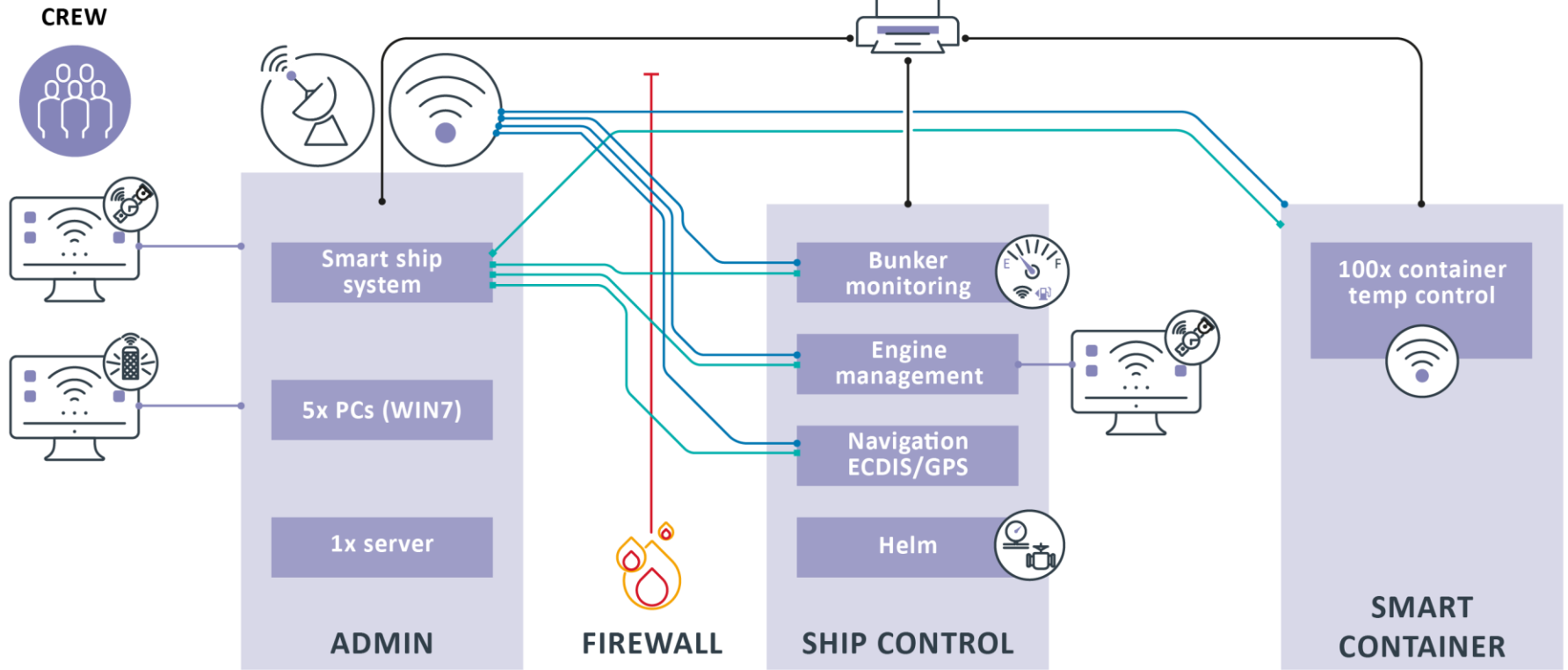
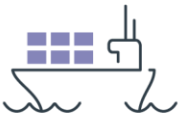

Critical infrastructure concerns

90% of manufactured goods travel by ship International Maritime Organisation

Sealift, either through Defence-owned shipping or *hired commercial shipping*, is the most cost-effective means and only real practicable method of deploying at scale to even land locked countries. UK Department of Defence JDP0-10

Shipping is the life blood of the global economy. Without shipping, intercontinental trade, the bulk transport of raw materials, and the import/export of affordable food and manufactured goods would simply not be possible. International Chamber of Shipping

Industry factors help and hinder

Safety

Regulation

Enforcement

Environment



Legacy

Longevity

Flag states

Builders

Specialist manufacturers

Componentisation

ICS trust model

The IoT in the maritime environment

Connects a “hostile” ICS environment with associated risks

Shows an accelerating adoption trend

Provokes a regulatory response related to critical infrastructure

Batten down the hatches

Questions?



Andy Jones CISSP

Distinguished Analyst

andy.jones@securityforum.org

Web: securityforum.org

Twitter: [@securityforum](https://twitter.com/securityforum)

LinkedIn: www.linkedin.com/in/andy-jones-5350111

SECURING THE IOT

TAMING THE CONNECTED WORLD

Download our briefing paper today

© Information Security Forum Ltd 2019. All rights reserved.



<http://ow.ly/ZNnC50xqg8t>

Thank you

isflive.org
securityforum.org